

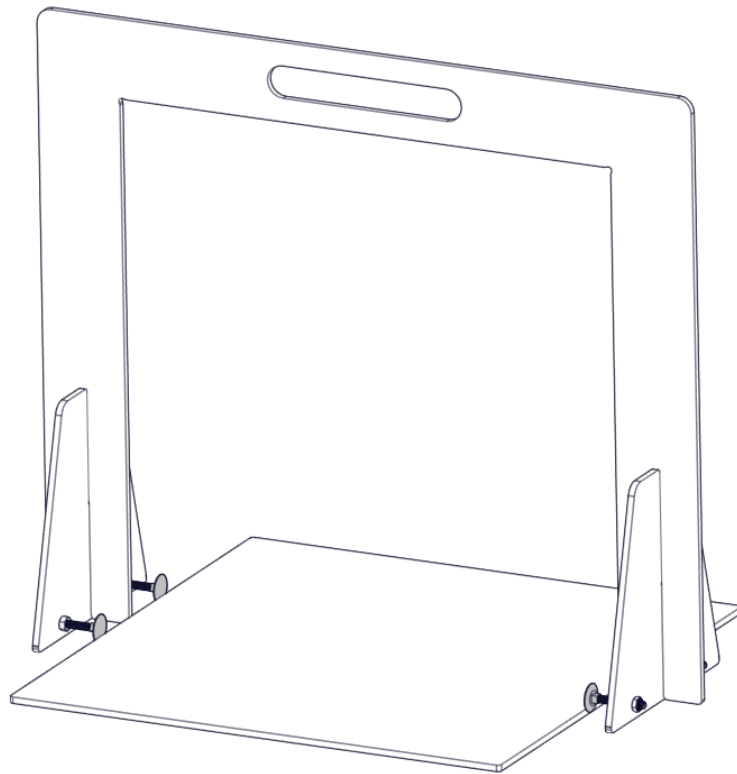

FTC Sizing Tool

(am-3870)

Usage Guide



Revision #	Date	Author	Purpose
0	3/17/2026	E. Scime	Original Document

P. Yeung	3/17/2026
Reviewer Name	Date Reviewed

Need help with an AndyMark product? Contact us at support@andymark.com.

Step 1

Insert the two trapezoidal supports (am-3870_support) into the handle (am-3870_U).

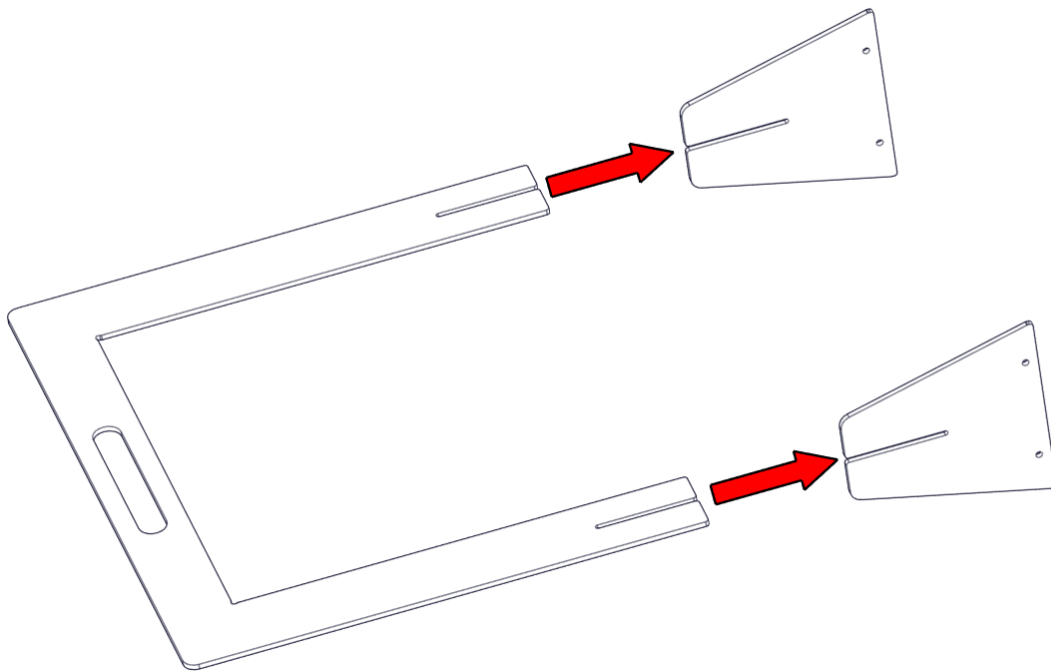

Step 2

Place the assembly around the baseplate (am-3870_BasePlate).

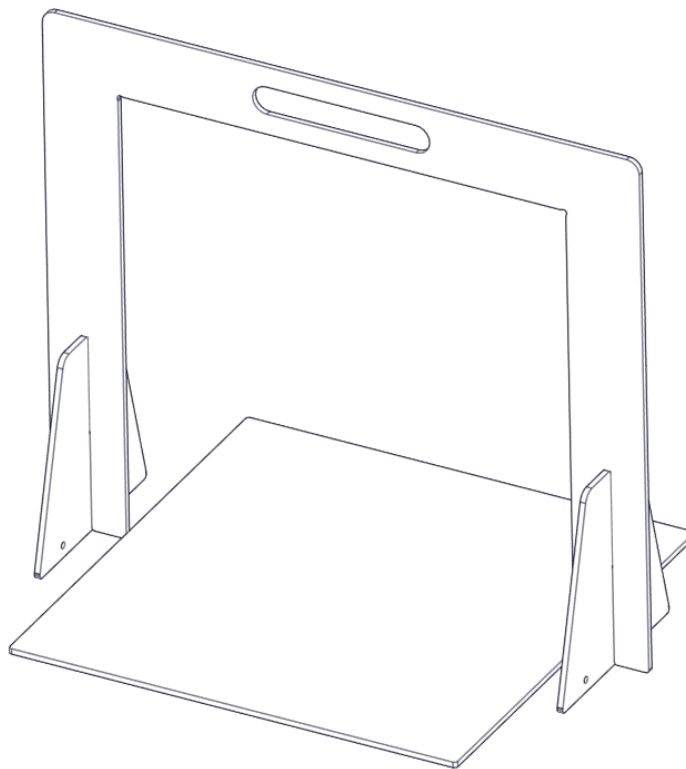

Step 3

Install [4] 2" long 1/4-20 elevator bolts (am-1621) into the supports and [1] 1/4-20 nut (am-1487) each. Place them such that the structure will glide smoothly along the edge of the baseplate and unscrew the nut until that spacing is correct. Then screw on [1] 1/4-20 nylock nut (am-1102) onto each screw to secure each screw in place.

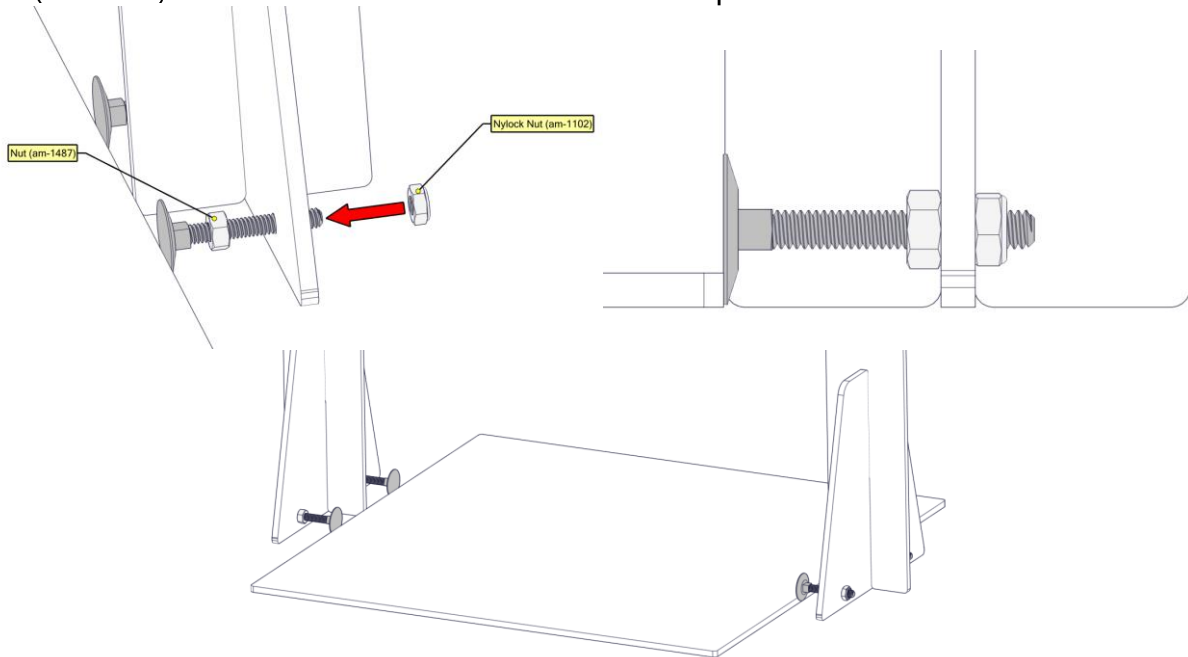

Step 4

Place the robot on the baseplate and slide the handle assembly back and forth to check size compliance.

